



## Table of Contents

Special Characteristics, Points of Caution  
in Selecting and Using Helical Gears ..... page 130  
KHG Ground Helical Gears ..... page 134  
SH Helical Gears ..... page 144

## Catalog Number of KHK Stock Gears

The Catalog Number for KHK stock gears is based on the simple formula listed below.  
Please order KHK gears by specifying the Catalog Numbers.

(Example)

Helical Gears

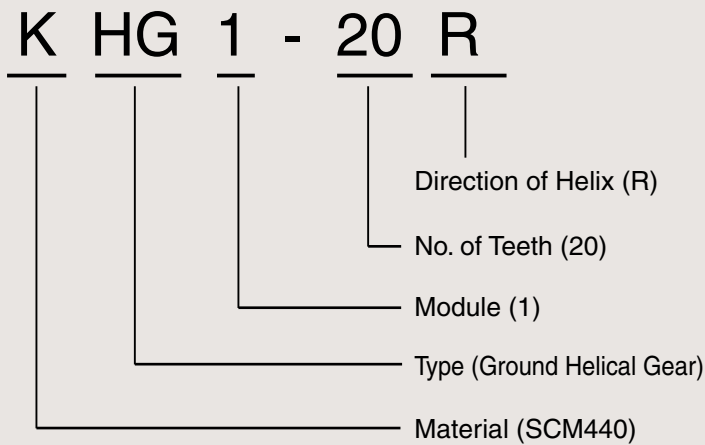

Material  
S S45C  
K SCM440

Type  
H Helical Gears  
HG Ground Helical Gear

# 2

# Helical Gears





# Helical Gears

## Meets all high-speed rotation needs of industrial machines!



### Characteristics

KHK stock helical gears are quiet, compact and economical. They are suitable wherever you require high-speed rotation including in machine tools, speed reducers and other industrial machinery.

#### ■ KHG Ground Helical Gears

- ① Have excellent strength and wear resistance which allow your designs to be more compact.
- ② Secondary operations are possible permitting modifications to suit your design.
- ③ Use of a transverse module allows interchangeability with straight spur gears of the same module and numbers of teeth at the same center distance. This feature is very convenient when switching from spur gears to helical gears due to the gear strength or the noise considerations.
- ④ The use of CBN grinding wheels produces consistent precision with shorter grinding time, making these products easily affordable.



#### ■ SH Helical Gears

- ① SH helical gears fit a wide range of applications which have made them popular choices for many years.
- ② Since helical gears have larger contact ratios than the equivalent SS spur gears, they are effective in reducing noise and vibration.



### Selection Hints

It is important to thoroughly understand the contents of the product tables as well as “CAUTION” notes before making the selection. You must specify the right or left hand by including the letter R or L in the catalog number when ordering.

#### 1. Caution in Selecting the Mating Gears.

Right hand and left hand helical gears mate as a set. See the photograph for reference. The table shows the possible combinations.

#### ■ Mating Helical Gear Selection Chart (○ Allowable × Not allowable)

Catalog No. & Helix Hand	KHG		SH		KRHG(F)		SRH		
	RH	LH	RH	LH	RH	LH	RH	LH	
KHG	RH	×	○	×	×	×	○	×	×
	LH	○	×	×	×	○	×	×	×
SH	RH	×	×	×	○	×	×	×	○
	LH	×	×	○	×	×	×	○	×

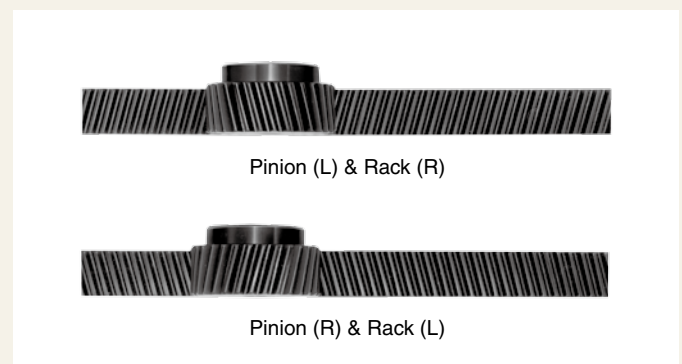
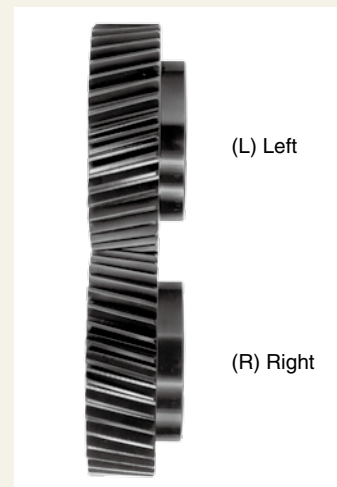



## 2. Caution in Selecting Gears Based on Gear Strength

Allowable bending strength and surface durability values shown in product tables were computed by assuming a certain application environment. They should be used as reference only. We recommend that each user computes his own values by applying the actual usage conditions.

### ■ Calculation of Bending Strength of Gears

Item	Catalog No.	KHG	SH
Formula <small>NOTE 1</small>		Formula of spur and helical gears on bending strength (JGMA401-01)	
No. of teeth of mating gears		Same number of teeth	
Rotation		600min <sup>-1</sup>	100min <sup>-1</sup>
Durability		Over 10 <sup>7</sup> cycles	
Impact from motor		Uniform load	
Impact from load		Uniform load	
Direction of load		Bidirectional	
Allowable bending stress at root $\sigma_{Flim}$ <small>NOTE 2</small>		20kgf/mm <sup>2</sup>	12.67kgf/mm <sup>2</sup>
Safety factor $S_F$		1.2	

### ■ Calculation of Surface Durability (Except where it is common with bending strength)

Formula <small>NOTE 1</small>	Formula of spur and helical gears on bending strength (JGMA402-01)	
Kinematic viscosity of lubricant	100cSt(50°C)	
Gear support	Symmetric support by bearings	
Allowable Hertz stress $\sigma_{Hlim}$	116kgf/mm <sup>2</sup>	49kgf/mm <sup>2</sup>
Safety factor $S_H$	1.15	

**NOTE 1:** The formula for gear strength is based on JGMA Standard. The units for the rotational speed (min<sup>-1</sup>) and the load (kgf/mm<sup>2</sup>) were matched to the units needed in the equation.

**NOTE 2:** Since the load is bidirectional, the allowable bending stress at root  $\sigma_{Flim}$  is set to 2/3 of the value.

## 3. Caution with Regard to the Special Characteristics of Helical Gears

- ① KHG ground helical gears and SH helical gears are not interchangeable due to different module systems, pressure angle designations and helix angles. The illustration below shows the difference between the transverse module of KHG type and the normal module of SH type gears.

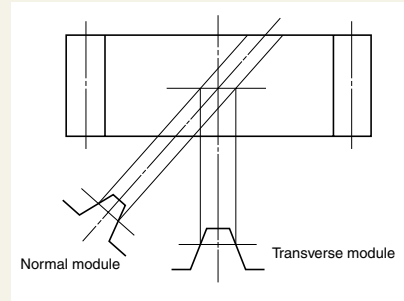

**CAUTION:** Above is for illustration purpose only and not a representation of the true tooth forms.

- ② Since SH helical gears use the normal module, the pitch circle diameters and the center distance are not integral numbers. Please refer to the Table of SH Helical Gear Center Distance on the product pages.

## 4. Other Points to Consider in Selection Process

- ① There are various footnotes to the product pages under the headings of “CAUTION” and “NOTE”. Please consider them carefully when selecting these products.
- ② There may be slight differences in color or shape of products shown in the photograph from the actual products.
- ③ KHK reserves the right to make changes in specifications and dimensions without notice.
- ④ KHK is ready to produce and supply custom order products. When you require specific gears different from KHK Stock Gears please contact our distributor for quotation. Also, please refer to page 16 “KHK Custom Order Products”.

### Definition of bending strength

The allowable bending strength of a gear is defined as the allowable tangential force at the pitch circle based on the mutually allowable root stress of two meshing gears under load.



Example of the failure due to insufficient bending strength.

### Definition of surface durability

The surface durability of a gear is defined as the allowable tangential force at the pitch circle, which permits the force to be transmitted safely without incurring surface failure.



Example of the defacement due to insufficient surface durability.



# Helical Gear



## Application Hints

In order to use KHK stock gears safely, carefully read the Application Hints before proceeding.

If there are questions or if you require clarifications, please contact our technical department or your nearest distributor.

KHK CO., LTD. TECHNICAL DEPARTMENT  
PHONE: 81-48-254-1744 FAX: 81-48-254-1765  
E-mail [export@khkgears.co.jp](mailto:export@khkgears.co.jp)

### 1. Caution on Performing Secondary Operations

Most KHK gears can be modified by the user. Please note the following points.

- ① If you are reboring, it is important to pay special attention to locating the center in order to avoid runout.
- ② The reference datum for gear cutting is the bore. Therefore, use the bore for locating the center. If it is too difficult to do for small bores, the alternative is to use one spot on the bore and the runout of the side surface.
- ③ If the rework requires using scroll chucks, we recommend the use of new or rebored jaws for improved precision. If chucking by the teeth, please apply the pressure carefully to avoid crushing the teeth which will lead to noisy gears.

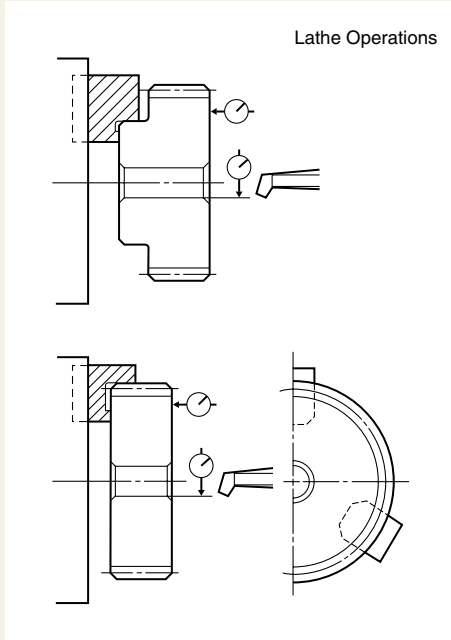

- ④ The maximum bore size is dictated by the requirement that the strength of the hub must be higher than that of the gear teeth.
- ⑤ In order to avoid stress concentrations, leave radii on the keyway corners.

Tapping & Keyway Slotting

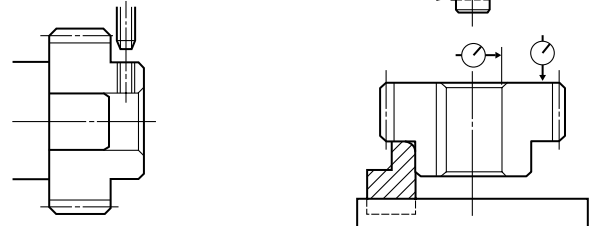

- ⑥ To avoid problems of reduced gear precision and other manufacturing difficulties, do not attempt to machine the gears to reduce face widths.
- ⑦ KHG Ground Helical Gears are already stress relieved. But if you subject them to a heavy turning operation such as removing the hubs, the residual stress may cause deformation.
- ⑧ When heat-treating SH Helical Gears, it is possible to get thermal stress cracks. It is best to subject them to penetrant inspection afterwards. If the tooth strength is not sufficient, it can be increased approximately four times by heat-treating. On the other hand, the precision of the gear will drop about one grade.

## Heat Treatment

- 1) Induction Heat treatment of S45C products should conform with the reference data below.
  - Heat treatment temperature - 800~900°C
  - Tempering temperature - 200~250°C
  - Hardness - 48~53HRC
- 2) In general, gears made from S45C have not been heat-treated. The user can heat-treat as required, but some deformation will be introduced. Ordinarily, a grinding process is needed after heat-treatment. Otherwise, the precision grade will drop about one grade.
- 3) SUS303 and SUS304 belong to austenite family and cannot be hardened. To harden stainless, there are martensitic series, such as SUS420J2.
- 4) The induction hardened depth is approximately 1mm. However, the hardening process does not completely reach the root of the gear tooth at the center portion of the face width.



## 2. Points of Caution in Assembling

- ① KHK stock helical gears are designed to give the proper backlash when assembled using the center distance given by the formula on the right (center distance tolerance of H7~H8). The amount of backlash is given in the product table for each gear.
- ② Because of the helix of the gear teeth, helical gears in mesh produce thrust forces in the axial directions. The axial thrust bearings must be able to resist these forces. The direction of the thrust forces depend on the helix hand and the direction of rotation as shown below
- ③ Please refer to overall length tolerance for Helical Gears on page 30.

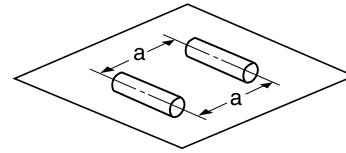

**CAUTION:**

The center distance of SH series is given in a separate table.

$$a = \frac{d_1 + d_2}{2}$$

where  
 a = center distance  
 d<sub>1</sub> = pitch diameter of pinion  
 d<sub>2</sub> = pitch diameter of gear

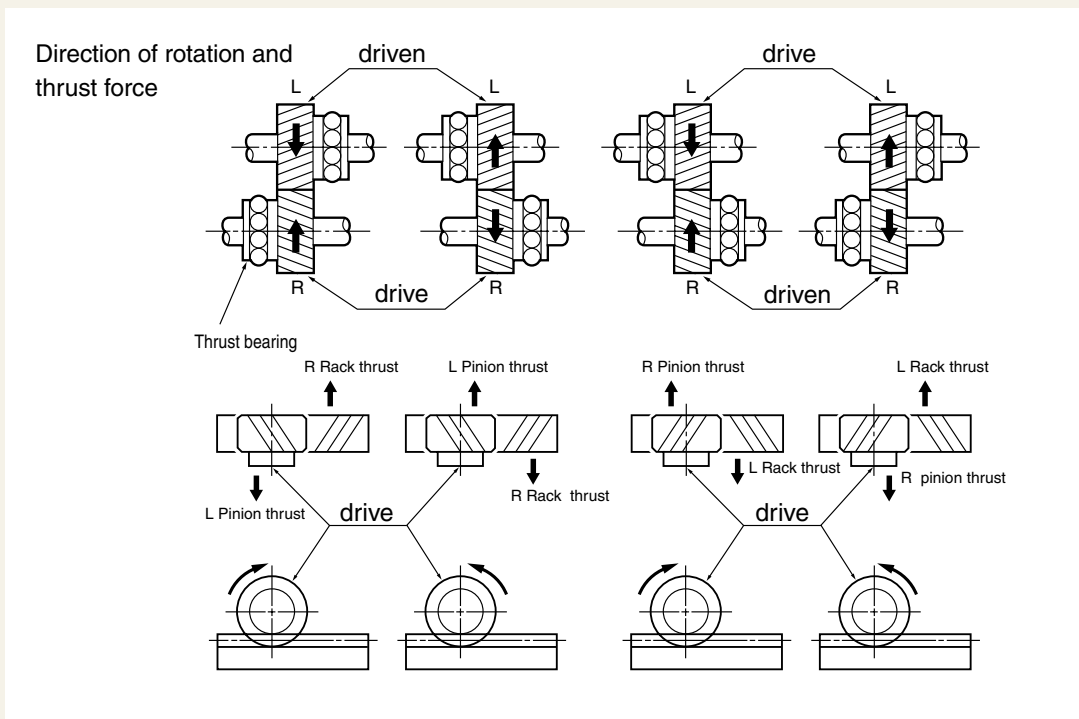

## 3. Notes on Starting Operations

- ① Before operating, check the following:
  - Are the gears firmly mounted on the shafts?
  - Have you eliminated uneven tooth contact?
  - Does the gear mesh have the proper amount of backlash?  
(Please avoid the condition of no backlash.)
  - Is there sufficient lubrication?
- ② If the gears are exposed, install a safety cover for protection. Never touch gears while they are in motion.
- ③ If there is unusual noise or vibration at the start up or insufficient lubrication after the start up, please recheck the gears and correctness of the assembly. Some of the methods for achieving noise reduction are:
  - (a) High Precision
  - (b) Fine Tooth Surface Finish
  - (c) Accurate Tooth Contact

- ④ The followings are the gear lubrication methods in general use:
  - (a) Grease Lubrication
  - (b) Splash Lubrication (Oil Bath Method)
  - (c) Forced Oil Circulation Lubrication
 Check lubrication after start up. Sometimes, when the unit is initially being operated, lubricating oil deteriorates rapidly.

## 4. Other Points to Consider in Applications

- ① KHK products are individually packaged to avoid damage. Depending on how they are handled, it is still possible to deform or break them. It is important to exercise care in handling these parts.
- ② Check the products as they are being taken out of the boxes. If any of them are rusted, scratched or dented, please return to the dealer where they were bought, for exchange.
- ③ KHK cannot guarantee the precision of gears once the customer performs a secondary operation on them.