



Shaft Orientations and Orientation Codes

There are 24 permutations of shaft orientations and rotations, which are standardized for CBX Bevel Gearboxes. Please pay attention to the shaft orientations in addition to the catalog number when selecting the units.

- CAUTION 1:** The diagrams below show the mounting surface.
- CAUTION 2:** The arrow marks on the shafts are intended to show the relative directions of rotation. The units can be driven in the opposite directions as well.
- CAUTION 3:** "▼" mark indications the surface on which the oiling and drain plugs are located when mounting horizontally. The ones without the marks have the plugs on the rear surface (Standard specifications).
- CAUTION 4:** When the unit (other than LI-LL Type, TE-TF Type) is used with the input shaft (X-axis) pointing up and is wall mounted, the lubrication method for the bearings must be altered. Please notify us at the time of placing your order.
- CAUTION 5:** For use other than mounting on a horizontal surface, please see page 365.

Features

- ① **Very strong**
The unit has high grade cast iron housing and uses tapered roller bearings.
- ② **Low noise and high efficiency**
The spiral bevel gears are made of case-hardened alloy steel.
- ③ **Freedom of installing orientation**
The unit can be installed easily in any orientation. However, if you cannot use one of the standard orientations, please see page 365.
- ④ **Maintenance-free**
High-grade oil is added to the casing before shipping.
- ⑤ **Selective speed ratio**
Gear ratios of 1/1 or 1/2 are available to meet most applications.

Lubrication

A standard volume of lubricant is sealed at the factory before shipping.

Model	Volume of lubricant	Lubrication	
CBX-19 Type	0.3L	Oil	JIS Gear oil Industrial Type 2
CBX-25 Type	0.7L		
CBX-32 Type	1.0L		
CBX-40 Type	1.5L		

Operating preconditions

See KBX (page 358)

CBX Shaft Orientations Chart

	CBX-L Type Diagram				CBX-T Type Diagram	
Horizontal Type (Top View)						
	A Type	B Type	C Type	D Type	A Type	B Type
	E Type	F Type	G Type	H Type	C Type	D Type
Vertical Type (Front View)						
	I Type	J Type	K Type	L Type	E Type	F Type
	M Type	N Type	O Type	P Type	G Type	H Type



CBX Performance Chart

Speed ratio	Type	Specifications	X-axis revolutions per minute (min ⁻¹)												
			20	50	100	200	300	400	600	900	1200	1500	1800	2500	3600
1 : 1	CBX-191	Allowable Power (kW)	0.08	0.20	0.39	0.77	1.15	1.50	2.05	2.67	3.30	3.95	4.40	4.40	4.40
		X&Y-axis torque (N·m) [kgf·m]	37.2 [3.8]	37.2 [3.8]	37.2 [3.8]	36.3 [3.7]	36.3 [3.7]	36.3 [3.6]	32.3 [3.3]	28.4 [2.9]	26.5 [2.7]	24.5 [2.5]	23.5 [2.4]	16.7 [1.7]	10.8 [1.1]
		X-axis O.H.L. (N) [kgf]	1760 [180]	1760 [180]	1760 [180]	1760 [180]	1670 [170]	1620 [165]	1270 [130]	1080 [110]	882 [90]	833 [85]	784 [80]	686 [70]	637 [65]
		Y-axis O.H.L. (N) [kgf]	1960 [200]	1960 [200]	1960 [200]	1960 [200]	1960 [200]	1810 [185]	1470 [150]	1180 [120]	1030 [105]	980 [100]	931 [95]	784 [80]	735 [75]
	CBX-251	Allowable Power (kW)	0.25	0.62	1.24	2.47	3.68	4.70	6.40	8.60	10.5	12.3	13.8	—	—
		X&Y-axis torque (N·m) [kgf·m]	118 [12.0]	118 [12.0]	118 [12.0]	118 [12.0]	116 [11.8]	112 [11.4]	101 [10.3]	91.1 [9.3]	83.3 [8.5]	78.4 [8.0]	73.5 [7.5]	—	—
		X-axis O.H.L. (N) [kgf]	3920 [400]	3920 [400]	3920 [400]	3920 [400]	3630 [370]	3330 [340]	2940 [300]	2450 [250]	2160 [220]	1960 [200]	1760 [180]	—	—
		Y-axis O.H.L. (N) [kgf]	4120 [420]	4120 [420]	4120 [420]	4120 [420]	4020 [410]	3920 [400]	3430 [350]	2940 [300]	2550 [260]	2450 [250]	2250 [230]	—	—
	CBX-321	Allowable Power (kW)	0.36	0.88	1.77	3.53	5.26	6.72	9.15	12.3	15.0	17.5	19.7	—	—
		X&Y-axis torque (N·m) [kgf·m]	167 [17.0]	167 [17.0]	167 [17.0]	167 [17.0]	165 [16.8]	160 [16.3]	144 [14.7]	130 [13.3]	119 [12.1]	112 [11.4]	104 [10.6]	—	—
		X-axis O.H.L. (N) [kgf]	4900 [500]	4900 [500]	4900 [500]	4900 [500]	4610 [470]	4210 [430]	3720 [380]	3140 [320]	2740 [280]	2450 [250]	2160 [220]	—	—
		Y-axis O.H.L. (N) [kgf]	5190 [530]	5190 [530]	5190 [530]	5190 [530]	5100 [520]	4900 [500]	4310 [440]	3720 [380]	3230 [330]	3140 [320]	2840 [290]	—	—
	CBX-401	Allowable Power (kW)	0.62	1.59	3.18	6.32	9.50	12.0	16.1	22.0	26.5	—	—	—	—
		X&Y-axis torque (N·m) [kgf·m]	294 [30.0]	294 [30.0]	294 [30.0]	294 [30.0]	294 [30.0]	284 [29.0]	255 [26.0]	231 [23.6]	211 [21.5]	—	—	—	—
		X-axis O.H.L. (N) [kgf]	9800 [1000]	9800 [1000]	9800 [1000]	7840 [800]	5880 [600]	4900 [500]	4410 [450]	3720 [380]	3430 [350]	—	—	—	—
		Y-axis O.H.L. (N) [kgf]	11760 [1200]	11760 [1200]	11760 [1200]	9800 [1000]	7350 [750]	6370 [650]	5880 [600]	5100 [520]	4020 [410]	—	—	—	—

Speed ratio	Type	Specifications	X-axis revolutions per minute (min ⁻¹)												
			20	50	100	200	300	400	600	900	1200	1500	1800	2500	3600
1 : 2	CBX-192	Allowable Power (kW)	0.03	0.07	0.14	0.27	0.40	0.53	0.78	1.15	1.50	1.85	2.17	2.20	2.20
		Y-axis torque (N·m) [kgf·m]	25.5 [2.6]	25.5 [2.6]	25.5 [2.6]	25.5 [2.6]	25.5 [2.6]	24.5 [2.5]	24.5 [2.5]	24.5 [2.5]	23.5 [2.4]	23.5 [2.4]	22.5 [2.3]	16.7 [1.7]	10.8 [1.1]
		X-axis O.H.L. (N) [kgf]	1180 [120]	1180 [120]	1180 [120]	1180 [120]	1180 [120]	1130 [115]	1130 [115]	1080 [110]	1080 [110]	882 [90]	833 [85]	784 [80]	735 [75]
		Y-axis O.H.L. (N) [kgf]	1760 [180]	1760 [180]	1760 [180]	1760 [180]	1760 [180]	1720 [175]	1670 [170]	1470 [150]	1270 [130]	1080 [110]	980 [100]	833 [85]	784 [80]
	CBX-252	Allowable Power (kW)	0.09	0.23	0.45	0.90	1.34	1.78	2.67	4.00	5.30	6.33	7.50	7.50	—
		Y-axis torque (N·m) [kgf·m]	85.3 [8.7]	85.3 [8.7]	85.3 [8.7]	85.3 [8.7]	85.3 [8.7]	84.3 [8.6]	84.3 [8.6]	84.3 [8.6]	84.3 [8.6]	80.4 [8.2]	79.4 [8.1]	56.8 [5.8]	—
		X-axis O.H.L. (N) [kgf]	3920 [400]	3920 [400]	3920 [400]	3920 [400]	3920 [400]	3720 [380]	3630 [370]	3530 [360]	3230 [330]	2740 [280]	2250 [230]	1670 [170]	—
		Y-axis O.H.L. (N) [kgf]	4120 [420]	4120 [420]	4120 [420]	4120 [420]	4020 [410]	3920 [400]	3820 [390]	3720 [380]	3430 [350]	3040 [310]	2650 [270]	2350 [240]	—
	CBX-322	Allowable Power (kW)	0.13	0.32	0.64	1.28	1.91	2.54	3.80	5.72	7.57	9.05	10.7	—	—
		Y-axis torque (N·m) [kgf·m]	123 [12.5]	123 [12.5]	123 [12.5]	123 [12.5]	122 [12.4]	122 [12.4]	121 [12.3]	121 [12.3]	120 [12.2]	115 [11.7]	114 [11.6]	—	—
		X-axis O.H.L. (N) [kgf]	4900 [500]	4900 [500]	4900 [500]	4900 [500]	4900 [500]	4700 [480]	4610 [470]	4410 [450]	4120 [420]	3430 [350]	2840 [290]	—	—
		Y-axis O.H.L. (N) [kgf]	5190 [530]	5190 [530]	5190 [530]	5190 [530]	5100 [520]	4900 [500]	4800 [490]	4700 [480]	4310 [440]	3820 [390]	3330 [340]	—	—
	CBX-402	Allowable Power (kW)	0.20	0.48	0.96	1.93	2.90	3.84	5.72	8.55	11.0	13.8	16.4	—	—
		Y-axis torque (N·m) [kgf·m]	183 [18.7]	183 [18.7]	183 [18.7]	183 [18.7]	183 [18.7]	182 [18.6]	181 [18.5]	180 [18.4]	174 [17.8]	173 [17.6]	172 [17.5]	—	—
		X-axis O.H.L. (N) [kgf]	9800 [1000]	9800 [1000]	9800 [1000]	9800 [1000]	9800 [1000]	8820 [900]	7840 [800]	6860 [700]	5880 [600]	4900 [500]	3920 [400]	—	—
		Y-axis O.H.L. (N) [kgf]	11760 [1200]	11760 [1200]	11760 [1200]	11760 [1200]	11760 [1200]	9800 [1000]	8820 [900]	8820 [900]	8820 [900]	7840 [800]	6860 [700]	—	—

- CAUTION 1:** Be sure not to exceed the allowable torque values. Units with (1:2) reduction ratio have the slower speed in the Y-axis.
- CAUTION 2:** The values in the table are in effect when the service factor is 1. When the units are used under other conditions, refer to the Service Factor Tables 2 and 3 (page 356).
- CAUTION 3:** Overhang load (O.H.L.) means the load applied to the middle of the overhang shaft, perpendicular to the axis. When using the units under other conditions, refer to the factors K1 and K2 described in Tables 2 and 3 (page 356).
- CAUTION 4:** When the 1:2 speed ratio unit is used as a speed increaser (from the Y-axis to the X-axis), the X-axis torque becomes one half of the Y-axis torque shown in the table.
- CAUTION 5:** The Y-axis torque of CBX-T Type is the sum of the values on both right and left axis.
- CAUTION 6:** The Y-axis O.H.L. of CBX-T Type is the sum of the values on both right and left axis.
- CAUTION 7:** The allowable thrust load is half of O.H.L. value in each case.

Other Products
XBC



CBX Bevel Gearboxes

CBX L Type

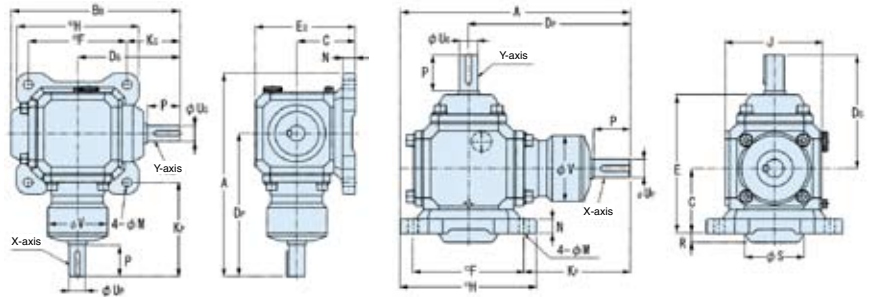

LA, LB Type
(LC, LD Type)

LE, LF Type
(LG, LH Type)

Catalog No.	Speed ratio	A	B _B	C	D _P	D _G	E	E _O	F	H	J	K _P	K _G	φ M	N	P	R	φ S
CBX-191L <input type="checkbox"/>	1:1	257	193	76	180	116	146	129	125	154	109	117.5	53.5	10.5	17	38	—	—
CBX-192L <input type="checkbox"/>	1:2																	
CBX-251L <input type="checkbox"/>	1:1	316	259	90	222	157	177.5	155	152	188	133	146	81	14	20	50	12	82.5
CBX-252L <input type="checkbox"/>	1:2																	
CBX-321L <input type="checkbox"/>	1:1	340	277	100	242	168	192.5	174	160	196	151	162	88	14	20	55	9	88.5
CBX-322L <input type="checkbox"/>	1:2																	
CBX-401L <input type="checkbox"/>	1:1	425	337	115	308	208	225	200	195	234	173	210.5	110.5	14	22	75	14	114.5
CBX-402L <input type="checkbox"/>	1:2																	

CAUTION: Please place one of the orientation codes (A-P) from page 362 on the box at the end of the catalog number.

CBX T Type

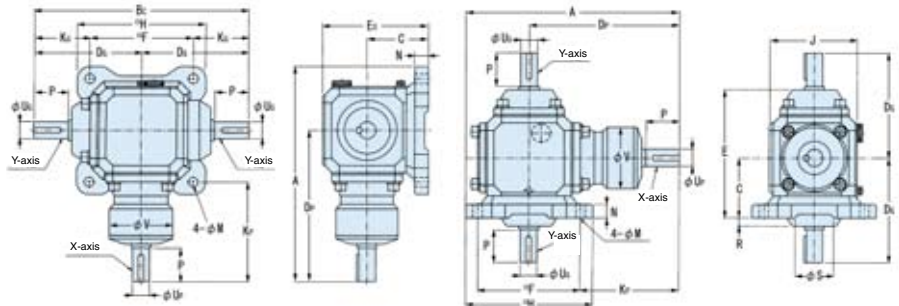

TA, TB Type

TC, TD Type

Catalog No.	Speed ratio	A	B _C	C	D _P	D _G	E	E _O	F	H	J	K _P	K _G	φ M	N	P	R	φ S
CBX-191T <input type="checkbox"/>	1:1	257	232	76	180	116	146	129	125	154	109	117.5	53.5	10.5	17	38	—	—
CBX-192T <input type="checkbox"/>	1:2																	
CBX-251T <input type="checkbox"/>	1:1	316	314	90	222	157	175.5	155	152	188	133	146	81	14	20	50	12	82.5
CBX-252T <input type="checkbox"/>	1:2																	
CBX-321T <input type="checkbox"/>	1:1	340	336	100	242	168	192.5	174	160	196	151	162	88	14	20	55	9	88.5
CBX-322T <input type="checkbox"/>	1:2																	
CBX-401T <input type="checkbox"/>	1:1	425	416	115	308	208	225	200	195	234	173	210.5	110.5	14	22	75	14	114.5
CBX-402T <input type="checkbox"/>	1:2																	

CAUTION: Please place one of the orientation codes (A-H) from page 362 on the box at the end of the catalog number.

Since these products are assembled to each customer's specifications, the delivery takes several days. These units are not available from stock.

