

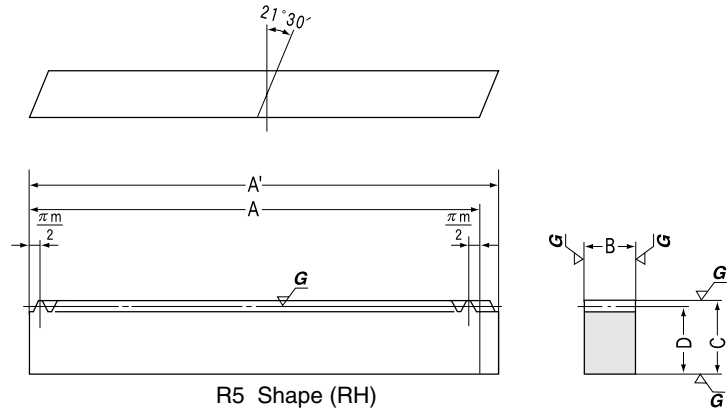

KRHG(F) Ground Helical Racks Transverse Modules 1~3

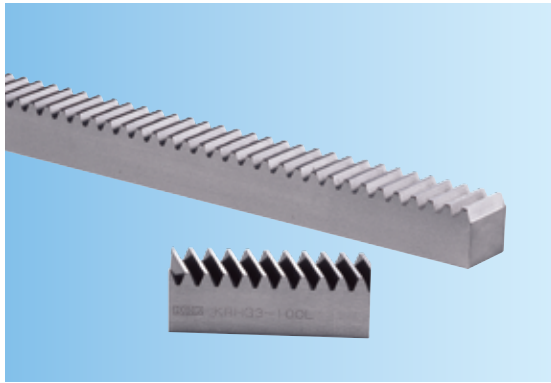

Transverse Modules 1~3

Catalog No.	Transverse module m	Direction of Helix <small>NOTE 1</small>	Total length	Face width		Height	Height to pitch line	Effective No. of teeth	Shape	Allowable force (N) <small>NOTE 2</small>		Allowable force (kgf)		Weight (kgf)
				A	B					Bending strength	Surface durability	Bending strength	Surface durability	
KRHG1 -100R KRHG1 -100L	1	R L	98	8	15	14	28	R1	1285	955.1	(131)	(97.39)	0.088	
KRHG1.5-100R KRHG1.5-100L	1.5	R L	101	12	20	18.5	18	R1	2891	2380	(294.8)	(242.7)	0.17	
KRHG2 -100R KRHG2 -100L	2	R L	98	16	25	23	12	R1	5141	4232	(524.2)	(431.5)	0.29	
KRHG2.5-100R KRHG2.5-100L	2.5	R L	100	20	30	27.5	9	R1	8032	6612	(819)	(674.2)	0.43	
KRHG3 -100R KRHG3 -100L	3	R L	102	25	35	32	7	R1	12040	9807	(1228)	(1000)	0.63	

NOTE 1: The joining gauge rack for helical racks must have the opposite direction of helix from the joined rack sections.

Transverse Modules 1~3 Type F

Catalog No.	Transverse module m	Direction of Helix	Total length	Face width		Height	Height to pitch line	Effective No. of teeth	Shape	Allowable force (N) <small>NOTE 2</small>		Allowable force (kgf)	
				A(A')	B					Bending strength	Surface durability	Bending strength	Surface durability
KRHGF1 - 500R KRHGF1 - 500L	1	R L	499.51 (502.66)	8	15	14	159	R5 R6	1285	955.1	(131)	(97.39)	
KRHGF1.5- 500R KRHGF1.5- 500L	1.5	R L	499.51 (504.24)	12	20	18.5	106	R5 R6	2891	2380	(294.8)	(242.7)	
KRHGF2 -1000R KRHGF2 -1000L	2	R L	1005.31 (1011.61)	16	25	23	160	R5 R6	5141	4232	(524.2)	(431.5)	
KRHGF2.5-1000R KRHGF2.5-1000L	2.5	R L	1005.31 (1013.19)	20	30	27.5	128	R5 R6	8032	6612	(819)	(674.2)	
KRHGF3 -1000R KRHGF3 -1000L	3	R L	999.03 (1008.88)	25	35	32	106	R5 R6	12040	9807	(1228)	(1000)	

CAUTION: Please use the KHG series of ground helical gears to mate with these racks. RH and LH mate as a pair.

CAUTION: Helical racks produce side thrust forces. Please see the application notes for helical gears on page 133.

NOTE 2: The allowable forces shown in the table are the calculated values according to assumed usage conditions. Please see page 155 for more details.

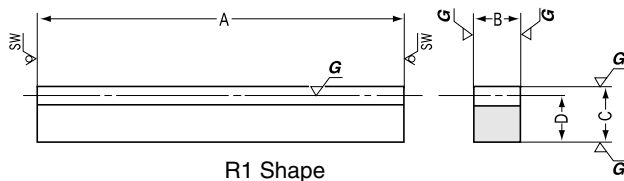
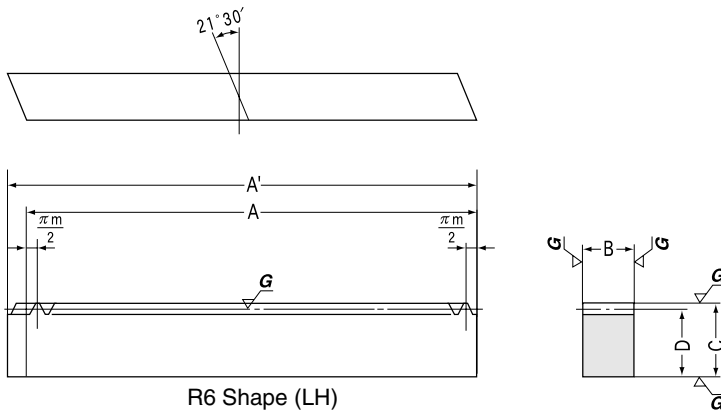

*SW is saw blade finish.

Specifications

Precision grade	KHK R 001 grade 1	Heat treatment	Thermal refining only
Reference section of gear	Rotating plane	Tooth hardness	250~285HB
Gear teeth	Standard full depth	Surface treatment	—
Transverse pressure angle	20°	Tooth surface finish	Ground
Helix angle	21°30'	Datum reference surface for gear grinding	Bottom surface
Material	SCM440	Secondary Operations	Possible

Weight (kgf)	Catalog No.
0.44	KRHGF1 - 500R KRHGF1 - 500L
0.87	KRHGF1.5- 500R KRHGF1.5- 500L
2.9	KRHGF2 - 1000R KRHGF2 - 1000L
4.34	KRHGF2.5-1000R KRHGF2.5-1000L
6.27	KRHGF3 - 1000R KRHGF3 - 1000L