

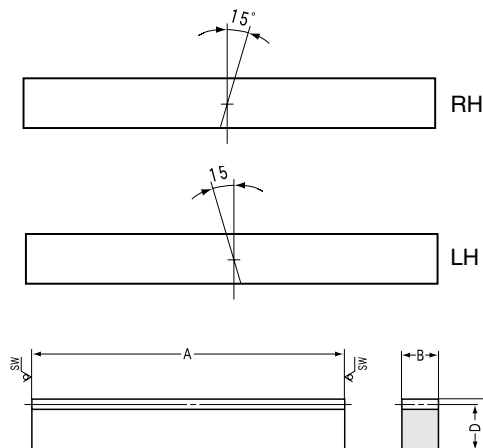

# SRH Helical Racks Normal Modules 2~3

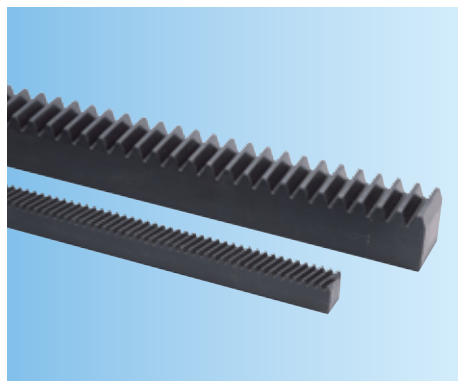

Specifications	
Precision grade	KHK R 001 grade 5
Reference section of gear	Normal plane
Gear teeth	Standard full depth
Normal pressure angle	20°
Helix angle	15°
Material	S45C-D
Heat treatment	Stress relief annealing
Tooth hardness	Less than 95HRB
Surface treatment	Black oxide
Tooth surface finish	Cut
Datum reference surface for gear cutting	Bottom surface
Secondary Operations	Possible

## Modules 2~3

R1 Shape \*SW is saw blade finish.

Catalog No.	Normal module <i>m</i>	Direction of Helix <small>NOTE 1</small>	Total length	Face width		Height	Height to pitch line	Effective No. of teeth	Shape	Allowable force (N) <small>NOTE 2</small>		Allowable force (kgf)	
				A	B					C	D	Bending strength	Surface durability
SRH2- 500R SRH2- 500L	2	R L	505	25	25	23	76	R1	4714	1569	( 480.7 )	( 160 )	
SRH3- 500R SRH3- 500L	3	R L	505	35	35	32	50	R1	9905	3518	( 1010 )	( 358.7 )	
SRH2-1000R SRH2-1000L	2	R L	1010	25	25	23	154	R1	4714	1569	( 480.7 )	( 160 )	
SRH3-1000R SRH3-1000L	3	R L	1010	35	35	32	102	R1	9905	3518	( 1010 )	( 358.7 )	

**NOTE 1:** Ordering the correct helix hand is important. For a right hand pinion, use a left hand rack and vice versa.

**NOTE 2:** The allowable forces shown in the table are the calculated values according to the assumed usage conditions. Please see page 155 for more details.

Weight (kgf)	Catalog No.
1.9	SRH2- 500R SRH2- 500L
3.8	SRH3- 500R SRH3- 500L
3.6	SRH2-1000R SRH2-1000L
7.6	SRH3-1000R SRH3-1000L