

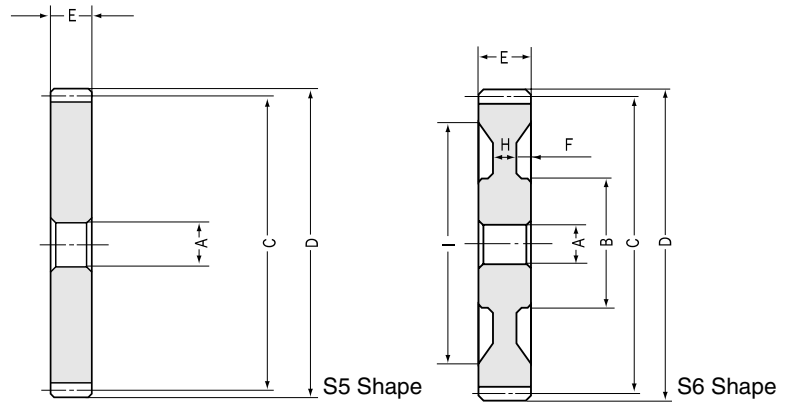

SSA Steel Hubless Spur Gears Module 1 ~ 1.5

Spur Gears

A 505



Module 1

Catalog No.	Module	No. of teeth	Bore NOTE 1	Hub dia.	Pitch dia.	Outside dia.	Face width	Hub width	Web thickness	Web O.D.
	m	z	AH7	B	C	D	E	F	H	I
SSA1- 20	1	20	8	—	20	22	10	—	—	—
SSA1- 24	1	24	8	—	24	26	10	—	—	—
SSA1- 25	1	25	8	—	25	27	10	—	—	—
SSA1- 28	1	28	8	—	28	30	10	—	—	—
SSA1- 30	1	30	8	—	30	32	10	—	—	—
SSA1- 32	1	32	8	—	32	34	10	—	—	—
SSA1- 35	1	35	8	—	35	37	10	—	—	—
SSA1- 36	1	36	8	—	36	38	10	—	—	—
SSA1- 40	1	40	8	—	40	42	10	—	—	—
SSA1- 45	1	45	8	—	45	47	10	—	—	—
SSA1- 48	1	48	8	—	48	50	10	—	—	—
SSA1- 50	1	50	10	—	50	52	10	—	—	—
SSA1- 55	1	55	10	—	55	57	10	—	—	—
SSA1- 56	1	56	10	—	56	58	10	—	—	—
SSA1- 60	1	60	10	—	60	62	10	—	—	—
SSA1- 70	1	70	10	—	70	72	10	—	—	—
SSA1- 80	1	80	10	—	80	82	10	—	—	—
SSA1-100	1	100	10	—	100	102	10	—	—	—
SSA1-120	1	120	10	—	120	122	10	—	—	—

Module 1.5

SSA1.5- 20	1.5	20	10	—	30	33	15	—	—	—
SSA1.5- 24	1.5	24	10	—	36	39	15	—	—	—
SSA1.5- 25	1.5	25	10	—	37.5	40.5	15	—	—	—
SSA1.5- 28	1.5	28	10	—	42	45	15	—	—	—
SSA1.5- 30	1.5	30	10	—	45	48	15	—	—	—
SSA1.5- 32	1.5	32	10	—	48	51	15	—	—	—
SSA1.5- 35	1.5	35	10	—	52.5	55.5	15	—	—	—
SSA1.5- 36	1.5	36	10	—	54	57	15	—	—	—
SSA1.5- 40	1.5	40	15	—	60	63	15	—	—	—
SSA1.5- 45	1.5	45	15	—	67.5	70.5	15	—	—	—
SSA1.5- 48	1.5	48	15	—	72	75	15	—	—	—
SSA1.5- 50	1.5	50	15	—	75	78	15	—	—	—
SSA1.5- 55	1.5	55	15	—	82.5	85.5	15	—	—	—
SSA1.5- 56	1.5	56	15	—	84	87	15	—	—	—
SSA1.5- 60	1.5	60	15	—	90	93	15	—	—	—
SSA1.5- 70	1.5	70	15	—	105	108	15	—	—	—
SSA1.5- 80	1.5	80	15	—	120	123	15	—	—	—
SSA1.5-100	1.5	100	15	70	150	153	15	3	9	133

NOTE 1: Please design the maximum bore so that the tooth strength is less than the strength of remaining material.



Steel, Hubless Spur Gears

Specifications

Precision grade	JIS N8 grade (JIS B1702-1: 1998) OLD JIS 4 grade (JIS B1702: 1976)	Tooth hardness	Less than 194HB
Gear teeth	Standard full depth	Surface treatment	Black oxide
Pressure angle	20°	Tooth surface finish	Cut
Material	S45C	Datum reference surface for gear cutting	Bore
Heat treatment	—	Secondary Operations	Possible

Shape	Allowable torque (N·m) NOTE 2		Allowable torque (kgf·m)		Backlash (mm) NOTE 3	Weight (kgf)	Catalog No.
	Bending strength	Surface durability	Bending strength	Surface durability			
S5	5.747	0.3275	(0.586)	(0.0334)	0.08 ~ 0.18	0.02	SSA1- 20
S5	7.469	0.4903	(0.7616)	(0.05)	0.1 ~ 0.22	0.03	SSA1- 24
S5	7.908	0.5364	(0.8064)	(0.0547)	0.1 ~ 0.22	0.04	SSA1- 25
S5	9.241	0.6816	(0.9423)	(0.0695)	0.1 ~ 0.22	0.04	SSA1- 28
S5	10.14	0.7894	(1.034)	(0.0805)	0.1 ~ 0.22	0.05	SSA1- 30
S5	11.05	0.9042	(1.127)	(0.0922)	0.1 ~ 0.22	0.06	SSA1- 32
S5	12.42	1.092	(1.267)	(0.1114)	0.1 ~ 0.22	0.07	SSA1- 35
S5	12.89	1.16	(1.314)	(0.1183)	0.1 ~ 0.22	0.08	SSA1- 36
S5	14.74	1.449	(1.503)	(0.1478)	0.1 ~ 0.22	0.1	SSA1- 40
S5	17.08	1.857	(1.742)	(0.1894)	0.12 ~ 0.26	0.12	SSA1- 45
S5	18.5	2.128	(1.887)	(0.217)	0.12 ~ 0.26	0.14	SSA1- 48
S5	19.45	2.319	(1.983)	(0.2365)	0.12 ~ 0.26	0.15	SSA1- 50
S5	21.83	2.833	(2.226)	(0.2889)	0.12 ~ 0.26	0.18	SSA1- 55
S5	22.31	2.942	(2.275)	(0.3)	0.12 ~ 0.26	0.19	SSA1- 56
S5	24.22	3.4	(2.47)	(0.3467)	0.12 ~ 0.26	0.22	SSA1- 60
S5	29.05	4.695	(2.962)	(0.4788)	0.12 ~ 0.26	0.3	SSA1- 70
S5	33.9	6.226	(3.457)	(0.6349)	0.12 ~ 0.26	0.39	SSA1- 80
S5	43.66	9.973	(4.452)	(1.017)	0.16 ~ 0.32	0.61	SSA1-100
S5	53.47	14.66	(5.452)	(1.495)	0.16 ~ 0.32	0.88	SSA1-120

S5	19.4	1.154	(1.978)	(0.1177)	0.1 ~ 0.22	0.07	SSA1.5- 20
S5	25.21	1.732	(2.571)	(0.1766)	0.12 ~ 0.26	0.11	SSA1.5- 24
S5	26.69	1.897	(2.722)	(0.1934)	0.12 ~ 0.26	0.12	SSA1.5- 25
S5	31.18	2.409	(3.18)	(0.2457)	0.12 ~ 0.26	0.15	SSA1.5- 28
S5	34.22	2.787	(3.49)	(0.2842)	0.12 ~ 0.26	0.17	SSA1.5- 30
S5	37.28	3.192	(3.802)	(0.3255)	0.12 ~ 0.26	0.2	SSA1.5- 32
S5	41.92	3.854	(4.275)	(0.393)	0.12 ~ 0.26	0.24	SSA1.5- 35
S5	43.48	4.089	(4.434)	(0.417)	0.12 ~ 0.26	0.26	SSA1.5- 36
S5	49.75	5.1	(5.073)	(0.5201)	0.12 ~ 0.26	0.31	SSA1.5- 40
S5	57.66	6.527	(5.88)	(0.6656)	0.14 ~ 0.32	0.4	SSA1.5- 45
S5	62.44	7.473	(6.367)	(0.762)	0.14 ~ 0.32	0.46	SSA1.5- 48
S5	65.65	8.147	(6.694)	(0.8308)	0.14 ~ 0.32	0.5	SSA1.5- 50
S5	73.68	9.963	(7.513)	(1.016)	0.14 ~ 0.32	0.61	SSA1.5- 55
S5	75.29	10.36	(7.678)	(1.056)	0.14 ~ 0.32	0.63	SSA1.5- 56
S5	81.77	11.97	(8.338)	(1.221)	0.14 ~ 0.32	0.7	SSA1.5- 60
S5	98.04	16.57	(9.997)	(1.69)	0.14 ~ 0.32	1	SSA1.5- 70
S5	114.4	22	(11.67)	(2.243)	0.14 ~ 0.32	1.2	SSA1.5- 80
S6	147.4	35.46	(15.03)	(3.616)	0.18 ~ 0.38	1.6	SSA1.5-100

NOTE 2: The allowable torques shown in the table are calculated values according to the assumed usage conditions. Please see page 27 for more details.

NOTE 3: The backlash values shown in the table are the theoretical values of a pair of identical gears in mesh.



SSA Steel Hubless Spur Gears Modules 2~2.5

Spur Gears

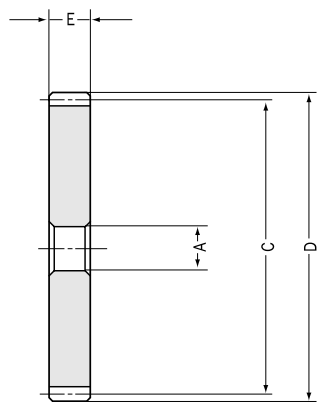

S5 Shape

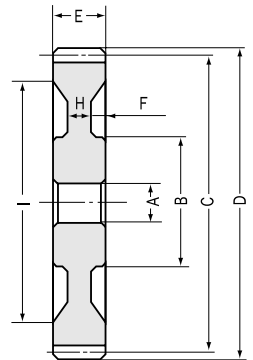

S6 Shape

Module 2

Catalog No.	Module	No. of teeth	Bore NOTE 1	Hub dia.	Pitch dia.	Outside dia.	Face width	Hub width	Web thickness	Web O.D.
	m	z	A _{H7}	B	C	D	E	F	H	I
SSA2- 20	2	20	12	—	40	44	20	—	—	—
SSA2- 24	2	24	12	—	48	52	20	—	—	—
SSA2- 25	2	25	12	—	50	54	20	—	—	—
SSA2- 28	2	28	15	—	56	60	20	—	—	—
SSA2- 30	2	30	15	—	60	64	20	—	—	—
SSA2- 32	2	32	15	—	64	68	20	—	—	—
SSA2- 35	2	35	15	—	70	74	20	—	—	—
SSA2- 36	2	36	15	—	72	76	20	—	—	—
SSA2- 40	2	40	18	—	80	84	20	—	—	—
SSA2- 45	2	45	18	—	90	94	20	—	—	—
SSA2- 48	2	48	18	—	96	100	20	—	—	—
SSA2- 50	2	50	18	—	100	104	20	—	—	—
SSA2- 55	2	55	18	—	110	114	20	—	—	—
SSA2- 56	2	56	18	—	112	116	20	—	—	—
SSA2- 60	2	60	18	—	120	124	20	—	—	—
SSA2- 70	2	70	18	—	140	144	20	—	—	—
SSA2- 80	2	80	18	70	160	164	20	4	12	136
SSA2-100	2	100	18	90	200	204	20	4	12	176

Module 2.5

SSA2.5-20	2.5	20	15	—	50	55	25	—	—	—
SSA2.5-24	2.5	24	15	—	60	65	25	—	—	—
SSA2.5-25	2.5	25	15	—	62.5	67.5	25	—	—	—
SSA2.5-28	2.5	28	18	—	70	75	25	—	—	—
SSA2.5-30	2.5	30	18	—	75	80	25	—	—	—
SSA2.5-32	2.5	32	18	—	80	85	25	—	—	—
SSA2.5-35	2.5	35	18	—	87.5	92.5	25	—	—	—
SSA2.5-36	2.5	36	18	—	90	95	25	—	—	—
SSA2.5-40	2.5	40	22	—	100	105	25	—	—	—
SSA2.5-45	2.5	45	22	—	112.5	117.5	25	—	—	—
SSA2.5-48	2.5	48	22	—	120	125	25	—	—	—
SSA2.5-50	2.5	50	22	—	125	130	25	—	—	—
SSA2.5-55	2.5	55	22	—	137.5	142.5	25	—	—	—
SSA2.5-56	2.5	56	22	—	140	145	25	—	—	—
SSA2.5-60	2.5	60	22	70	150	155	25	5	15	121
SSA2.5-70	2.5	70	22	80	175	180	25	5	15	146
SSA2.5-80	2.5	80	22	90	200	205	25	5	15	171

NOTE 1: Please design the maximum bore so that the tooth strength is less than the strength of remaining material.



Specifications

Precision grade	JIS N8 grade (JIS B1702-1: 1998) OLD JIS 4 grade (JIS B1702: 1976)	Tooth hardness	Less than 194HB
Gear teeth	Standard full depth	Surface treatment	Black oxide
Pressure angle	20°	Tooth surface finish	Cut
Material	S45C	Datum reference surface for gear cutting	Bore
Heat treatment	—	Secondary Operations	Possible

Shape	Allowable torque (N·m) <small>NOTE 2</small>		Allowable torque (kgf·m)		Backlash (mm) <small>NOTE 3</small>	Weight (kgf)	Catalog No.
	Bending strength	Surface durability	Bending strength	Surface durability			
S5	45.97	2.827	(4.688)	(0.2883)	0.12 ~ 0.26	0.18	SSA2- 20
S5	59.75	4.238	(6.093)	(0.4322)	0.14 ~ 0.3	0.27	SSA2- 24
S5	63.26	4.638	(6.451)	(0.4729)	0.14 ~ 0.3	0.29	SSA2- 25
S5	73.92	5.885	(7.538)	(0.6001)	0.14 ~ 0.3	0.35	SSA2- 28
S5	81.12	6.801	(8.272)	(0.6935)	0.14 ~ 0.3	0.42	SSA2- 30
S5	88.39	7.784	(9.013)	(0.7938)	0.14 ~ 0.3	0.49	SSA2- 32
S5	99.34	9.39	(10.13)	(0.9575)	0.14 ~ 0.3	0.58	SSA2- 35
S5	103.1	9.963	(10.51)	(1.016)	0.14 ~ 0.3	0.6	SSA2- 36
S5	117.9	12.45	(12.02)	(1.27)	0.14 ~ 0.3	0.78	SSA2- 40
S5	136.7	15.97	(13.94)	(1.628)	0.18 ~ 0.36	0.96	SSA2- 45
S5	148	18.3	(15.09)	(1.866)	0.18 ~ 0.36	1.1	SSA2- 48
S5	155.6	19.94	(15.87)	(2.033)	0.18 ~ 0.36	1.2	SSA2- 50
S5	174.7	24.36	(17.81)	(2.484)	0.18 ~ 0.36	1.5	SSA2- 55
S5	178.5	25.3	(18.2)	(2.58)	0.18 ~ 0.36	1.6	SSA2- 56
S5	193.8	29.33	(19.76)	(2.991)	0.18 ~ 0.36	1.9	SSA2- 60
S5	232.4	40.81	(23.7)	(4.161)	0.18 ~ 0.36	2.6	SSA2- 70
S6	271.2	54.26	(27.65)	(5.533)	0.18 ~ 0.36	2.3	SSA2- 80
S6	291.1	72.74	(29.68)	(7.418)	0.2 ~ 0.44	3.5	SSA2-100

S5	89.79	5.656	(9.156)	(0.5768)	0.14 ~ 0.28	0.33	SSA2.5-20
S5	116.7	8.465	(11.9)	(0.8632)	0.16 ~ 0.34	0.52	SSA2.5-24
S5	123.6	9.259	(12.6)	(0.9442)	0.16 ~ 0.34	0.57	SSA2.5-25
S5	144.4	11.74	(14.72)	(1.197)	0.16 ~ 0.34	0.71	SSA2.5-28
S5	158.5	13.58	(16.16)	(1.385)	0.16 ~ 0.34	0.82	SSA2.5-30
S5	172.6	15.56	(17.6)	(1.587)	0.16 ~ 0.34	0.94	SSA2.5-32
S5	194.1	18.81	(19.79)	(1.918)	0.16 ~ 0.34	1.1	SSA2.5-35
S5	201.3	19.96	(20.53)	(2.035)	0.16 ~ 0.34	1.2	SSA2.5-36
S5	230.4	24.92	(23.49)	(2.541)	0.16 ~ 0.34	1.5	SSA2.5-40
S5	266.9	31.92	(27.22)	(3.255)	0.18 ~ 0.4	1.8	SSA2.5-45
S5	289.1	36.67	(29.48)	(3.739)	0.18 ~ 0.4	2.1	SSA2.5-48
S5	303.9	40.02	(30.99)	(4.081)	0.18 ~ 0.4	2.4	SSA2.5-50
S5	341.1	49.08	(34.78)	(5.005)	0.18 ~ 0.4	2.8	SSA2.5-55
S5	348.6	51	(35.55)	(5.201)	0.18 ~ 0.4	3	SSA2.5-56
S6	378.5	59.1	(38.6)	(6.027)	0.18 ~ 0.4	2.3	SSA2.5-60
S6	453.8	82.07	(46.28)	(8.369)	0.18 ~ 0.4	3.9	SSA2.5-70
S6	441.4	90.93	(45.01)	(9.272)	0.18 ~ 0.4	4.5	SSA2.5-80

NOTE 2: The allowable torques shown in the table are calculated values according to the assumed usage conditions. Please see page 27 for more details.

NOTE 3: The backlash values shown in the table are the theoretical values of a pair of identical gears in mesh.



SSA Steel Hubless Spur Gears Modules 3~5

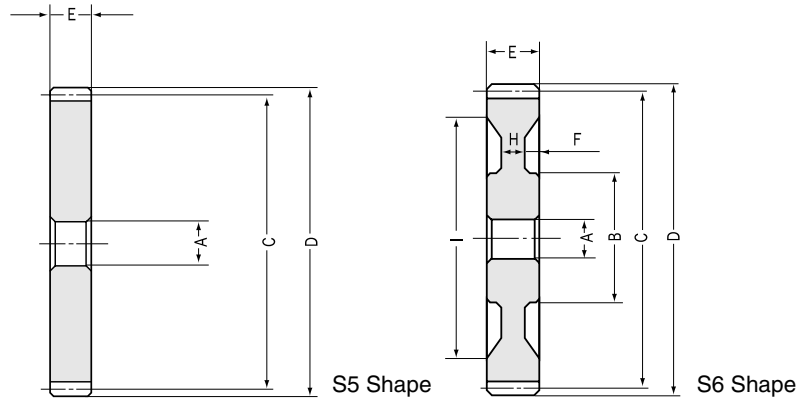

Module 3

Catalog No.	Module	No. of teeth	Bore NOTE 1	Hub dia.	Pitch dia.	Outside dia.	Face width	Hub width	Web thickness	Web O.D.
	m	z	A _{H7}	B	C	D	E	F	H	I
SSA3-20	3	20	15	—	60	66	30	—	—	—
SSA3-24	3	24	15	—	72	78	30	—	—	—
SSA3-25	3	25	15	—	75	81	30	—	—	—
SSA3-28	3	28	20	—	84	90	30	—	—	—
SSA3-30	3	30	20	—	90	96	30	—	—	—
SSA3-32	3	32	20	—	96	102	30	—	—	—
SSA3-35	3	35	20	—	105	111	30	—	—	—
SSA3-36	3	36	20	—	108	114	30	—	—	—
SSA3-40	3	40	25	—	120	126	30	—	—	—
SSA3-45	3	45	25	—	135	141	30	—	—	—
SSA3-48	3	48	25	—	144	150	30	—	—	—
SSA3-50	3	50	25	70	150	156	30	6	18	116
SSA3-55	3	55	25	80	165	171	30	6	18	131
SSA3-56	3	56	25	80	168	174	30	6	18	134
SSA3-60	3	60	25	90	180	186	30	6	18	146
SSA3-70	3	70	25	90	210	216	30	6	18	176
SSA3-80	3	80	25	90	240	246	30	6	18	205

Module 4

SSA4-20	4	20	20	—	80	88	40	—	—	—
SSA4-24	4	24	20	—	96	104	40	—	—	—
SSA4-25	4	25	20	—	100	108	40	—	—	—
SSA4-28	4	28	25	—	112	120	40	—	—	—
SSA4-30	4	30	25	—	120	128	40	—	—	—
SSA4-32	4	32	25	—	128	136	40	—	—	—
SSA4-35	4	35	25	—	140	148	40	—	—	—
SSA4-36	4	36	25	—	144	152	40	—	—	—
SSA4-40	4	40	30	80	160	168	40	7	26	118
SSA4-45	4	45	30	100	180	188	40	7	26	138
SSA4-48	4	48	30	100	192	200	40	7	26	150
SSA4-50	4	50	30	100	200	208	40	7	26	158
SSA4-55	4	55	30	110	220	228	40	7	26	178
SSA4-56	4	56	30	110	224	232	40	7	26	182
SSA4-60	4	60	30	120	240	248	40	7	26	198

Module 5

SSA5-20	5	20	22	—	100	110	50	—	—	—
SSA5-24	5	24	22	—	120	130	50	—	—	—
SSA5-25	5	25	22	—	125	135	50	—	—	—
SSA5-28	5	28	25	—	140	150	50	—	—	—
SSA5-30	5	30	25	—	150	160	50	—	—	—
SSA5-32	5	32	25	90	160	170	50	7	36	120
SSA5-35	5	35	25	90	175	185	50	7	36	130
SSA5-36	5	36	25	90	180	190	50	7	36	140
SSA5-40	5	40	30	100	200	210	50	7	36	160
SSA5-45	5	45	30	120	225	235	50	7	36	185
SSA5-48	5	48	30	120	240	250	50	7	36	200
SSA5-50	5	50	30	130	250	260	50	7	36	210

NOTE 1: Please design the maximum bore so that the tooth strength is less than the strength of remaining material.



Specifications

Precision grade	JIS N8 grade (JIS B1702-1: 1998) OLD JIS 4 grade (JIS B1702: 1976)	Tooth hardness	Less than 194HB
Gear teeth	Standard full depth	Surface treatment	Black oxide
Pressure angle	20°	Tooth surface finish	Cut
Material	S45C	Datum reference surface for gear cutting	Bore
Heat treatment	—	Secondary Operations	Possible

Shape	Allowable torque (N·m) <small>NOTE 2</small>		Allowable torque (kgf·m)		Backlash (mm) <small>NOTE 3</small>	Weight (kgf)	Catalog No.
	Bending strength	Surface durability	Bending strength	Surface durability			
S5	155.1	9.954	(15.82)	(1.015)	0.14 ~ 0.32	0.62	SSA3-20
S5	201.6	14.89	(20.56)	(1.518)	0.18 ~ 0.38	0.78	SSA3-24
S5	213.5	16.3	(21.77)	(1.662)	0.18 ~ 0.38	1	SSA3-25
S5	249.5	20.7	(25.44)	(2.111)	0.18 ~ 0.38	1.2	SSA3-28
S5	273.8	23.95	(27.92)	(2.442)	0.18 ~ 0.38	1.4	SSA3-30
S6	298.3	27.44	(30.42)	(2.798)	0.18 ~ 0.38	1.6	SSA3-32
S6	335.4	33.14	(34.2)	(3.379)	0.18 ~ 0.38	2	SSA3-35
S6	347.8	35.16	(35.47)	(3.585)	0.18 ~ 0.38	2.1	SSA3-36
S5	397.9	43.99	(40.58)	(4.486)	0.18 ~ 0.38	2.5	SSA3-40
S5	461.3	56.63	(47.04)	(5.775)	0.2 ~ 0.44	3.2	SSA3-45
S5	499.5	65.01	(50.94)	(6.629)	0.2 ~ 0.44	3.7	SSA3-48
S6	525.1	70.92	(53.55)	(7.232)	0.2 ~ 0.44	3.3	SSA3-50
S6	589.5	86.9	(60.11)	(8.861)	0.2 ~ 0.44	4.1	SSA3-55
S6	602.3	90.3	(61.42)	(9.208)	0.2 ~ 0.44	4.2	SSA3-56
S6	654.1	104.5	(66.7)	(10.66)	0.2 ~ 0.44	5.1	SSA3-60
S6	653.5	121.2	(66.64)	(12.36)	0.2 ~ 0.44	6.2	SSA3-70
S6	762.7	161.6	(77.77)	(16.48)	0.2 ~ 0.44	8.5	SSA3-80

S5	367.7	24.3	(37.5)	(2.478)	0.18 ~ 0.38	1.5	SSA4-20
S5	478.1	36.44	(48.75)	(3.716)	0.2 ~ 0.44	2.2	SSA4-24
S5	506.1	39.87	(51.61)	(4.066)	0.2 ~ 0.44	2.4	SSA4-25
S5	591.4	50.6	(60.31)	(5.16)	0.2 ~ 0.44	2.9	SSA4-28
S5	649	58.66	(66.18)	(5.982)	0.2 ~ 0.44	3.2	SSA4-30
S5	707.1	67.37	(72.1)	(6.87)	0.2 ~ 0.44	4.4	SSA4-32
S5	795	81.61	(81.07)	(8.322)	0.2 ~ 0.44	5.3	SSA4-35
S5	824.5	86.67	(84.08)	(8.838)	0.2 ~ 0.44	5.6	SSA4-36
S6	943.4	108.6	(96.2)	(11.07)	0.2 ~ 0.44	5.5	SSA4-40
S6	1093	139.4	(111.5)	(14.22)	0.24 ~ 0.52	7.3	SSA4-45
S6	986.5	133.3	(100.6)	(13.59)	0.24 ~ 0.52	8.2	SSA4-48
S6	1038	145.5	(105.8)	(14.84)	0.24 ~ 0.52	8.8	SSA4-50
S6	1164	178.7	(118.7)	(18.22)	0.24 ~ 0.52	10	SSA4-55
S6	1190	185.7	(121.3)	(18.94)	0.24 ~ 0.52	11	SSA4-56
S6	1293	215.4	(131.8)	(21.97)	0.24 ~ 0.52	13	SSA4-60

S5	718.3	48.63	(73.25)	(4.959)	0.2 ~ 0.44	2.9	SSA5-20
S5	933.7	73.02	(95.21)	(7.446)	0.24 ~ 0.5	4.2	SSA5-24
S5	988.5	80.04	(100.8)	(8.162)	0.24 ~ 0.5	4.6	SSA5-25
S5	1155	102	(117.8)	(10.4)	0.24 ~ 0.5	5.8	SSA5-28
S5	1268	118.2	(129.3)	(12.05)	0.24 ~ 0.5	6.6	SSA5-30
S6	1381	135.6	(140.8)	(13.83)	0.24 ~ 0.5	8.5	SSA5-32
S6	1552	164.2	(158.3)	(16.74)	0.24 ~ 0.5	10.2	SSA5-35
S6	1610	174.3	(164.2)	(17.77)	0.24 ~ 0.5	10.8	SSA5-36
S6	1536	181.8	(156.6)	(18.54)	0.24 ~ 0.5	11	SSA5-40
S6	1780	234.4	(181.5)	(23.9)	0.28 ~ 0.58	14	SSA5-45
S6	1927	269.3	(196.5)	(27.46)	0.28 ~ 0.58	15	SSA5-48
S6	2026	294	(206.6)	(29.98)	0.28 ~ 0.58	16	SSA5-50

NOTE 2: The allowable torques shown in the table are calculated values according to the assumed usage conditions. Please see page 27 for more details.

NOTE 3: The backlash values shown in the table are the theoretical values of a pair of identical gears in mesh.