

Center distance of Stock Spur Gears meshing with Profile Shifted Spur Gears

The table on the right shows the center distance of the spur gears ($x=0$) which can be meshed with profile shifted spur gears ($x=+0.5$) with module 1. Multiply by the actual module to determine your center distance.

Center distance when gear has 12 to 30 teeth (unit : mm)

No. of teeth ($x=+0.5$) No. of teeth ($x=0$)	10	11
12	11.4410	11.9428
13	11.9428	12.4446
14	12.4446	12.9462
15	12.9462	13.4477
16	13.4477	13.9492
17	13.9492	14.4505
18	14.4505	14.9518
19	14.9518	15.4530
20	15.4530	15.9542
21	15.9542	16.4553
22	16.4553	16.9564
23	16.9564	17.4574
24	17.4574	17.9583
25	17.9583	18.4592
26	18.4592	18.9601
27	18.9601	19.4610
28	19.4610	19.9618
29	19.9618	20.4625
30	20.4625	20.9633

Center distance when gear has 32 to 62 teeth (unit : mm)

No. of teeth ($x=+0.5$) No. of teeth ($x=0$)	10	11
32	21.4640	21.9647
34	22.4653	22.9660
35	22.9660	23.4666
36	23.4666	23.9671
38	24.4677	24.9683
40	25.4688	25.9693
42	26.4698	26.9703
44	27.4707	27.9712
45	27.9712	28.4716
46	28.4716	28.9721
48	29.4725	29.9729
50	30.4733	30.9736
52	31.4740	31.9744
54	32.4747	32.9750
55	32.9750	33.4754
56	33.4754	33.9757
58	34.4760	34.9763
60	35.4766	35.9769
62	36.4772	36.9774

Center distance when gear has 64 to 200 teeth (unit : mm)

No. of teeth ($x=+0.5$) No. of teeth ($x=0$)	10	11
64	37.4777	37.9780
65	37.9780	38.4782
66	38.4782	38.9785
68	39.4787	39.9790
70	40.4792	40.9794
72	41.4796	41.9799
75	42.9803	43.4805
76	43.4805	43.9807
80	45.4813	45.9814
84	47.4820	47.9822
85	47.9822	48.4823
88	49.4826	49.9828
90	50.4830	50.9831
95	52.9837	53.4838
100	55.4844	55.9845
120	65.4866	65.9867
150	80.4890	80.9890
200	105.4915	105.9915

Assembly distance of a profile shifted gear and the meshing rack

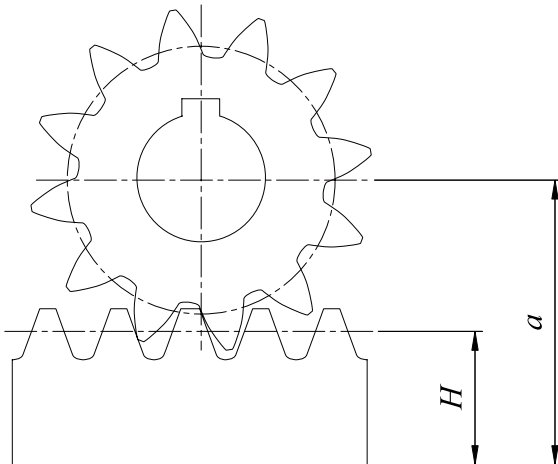

$$a = \frac{zm}{2} + H + xm$$

Where

a : Assembly Distance

H : Height of pitch line of rack

m : Module

z : No. of Teeth

x : Profile Shift Coefficient