

SUS 不銹鋼正齒輪

模數 1 ~ 1.5

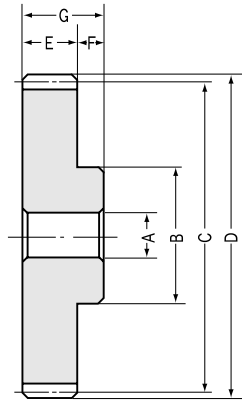

S1 形狀

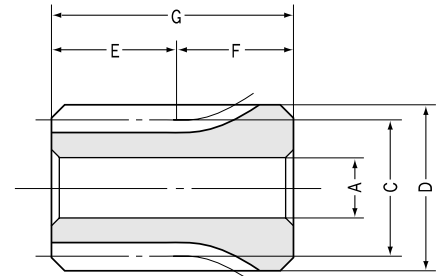

S3 形狀

模數 1

產品型號	模數	齒數	內徑	軀輪徑	節徑	齒頂圓直徑	齒幅	軀輪長	全長	端面寬度	腹板外徑
	m	z	A _{H7}	B	C	D	E	F	G	H	I
SUS1-15	1	15	8	17	15	17	10	20	30	—	—
SUS1-16	1	16	8	18	16	18	10	20	30	—	—
SUS1-18	1	18	8	20	18	20	10	20	30	—	—
SUS1-20	1	20	8	16	20	22	10	10	20	—	—
SUS1-22	1	22	8	18	22	24	10	10	20	—	—
SUS1-24	1	24	8	20	24	26	10	10	20	—	—
SUS1-25	1	25	8	20	25	27	10	10	20	—	—
SUS1-28	1	28	8	23	28	30	10	10	20	—	—
SUS1-30	1	30	8	25	30	32	10	10	20	—	—
SUS1-32	1	32	8	26	32	34	10	10	20	—	—
SUS1-35	1	35	8	26	35	37	10	10	20	—	—
SUS1-36	1	36	8	28	36	38	10	10	20	—	—
SUS1-40	1	40	10	35	40	42	10	10	20	—	—
SUS1-42	1	42	10	35	42	44	10	10	20	—	—
SUS1-45	1	45	10	35	45	47	10	10	20	—	—
SUS1-48	1	48	10	35	48	50	10	10	20	—	—
SUS1-50	1	50	10	35	50	52	10	10	20	—	—
SUS1-55	1	55	10	40	55	57	10	10	20	—	—
SUS1-56	1	56	10	40	56	58	10	10	20	—	—
SUS1-60	1	60	10	40	60	62	10	10	20	—	—
SUS1-64	1	64	10	45	64	66	10	10	20	—	—
SUS1-70	1	70	10	50	70	72	10	10	20	—	—
SUS1-75	1	75	10	55	75	77	10	10	20	—	—
SUS1-80	1	80	10	60	80	82	10	10	20	—	—
SUS1-90	1	90	10	60	90	92	10	10	20	—	—
SUS1-100	1	100	12	60	100	102	10	10	20	—	—
SUS1-120	1	120	12	60	120	122	10	10	20	—	—

模數 1.5

SUS1.5-15	1.5	15	8	18	22.5	25.5	15	14	29	—	—
SUS1.5-16	1.5	16	8	20	24	27	15	14	29	—	—
SUS1.5-18	1.5	18	8	22	27	30	15	14	29	—	—
SUS1.5-20	1.5	20	8	24	30	33	15	14	29	—	—
SUS1.5-22	1.5	22	8	26	33	36	15	14	29	—	—
SUS1.5-24	1.5	24	8	28	36	39	15	14	29	—	—
SUS1.5-25	1.5	25	8	30	37.5	40.5	15	14	29	—	—
SUS1.5-28	1.5	28	10	36	42	45	15	14	29	—	—
SUS1.5-30	1.5	30	10	38	45	48	15	14	29	—	—
SUS1.5-32	1.5	32	10	40	48	51	15	14	29	—	—
SUS1.5-35	1.5	35	10	42	52.5	55.5	15	14	29	—	—
SUS1.5-36	1.5	36	10	45	54	57	15	14	29	—	—
SUS1.5-40	1.5	40	12	45	60	63	15	14	29	—	—
SUS1.5-42	1.5	42	12	45	63	66	15	14	29	—	—
SUS1.5-45	1.5	45	12	45	67.5	70.5	15	14	29	—	—
SUS1.5-48	1.5	48	12	45	72	75	15	14	29	—	—
SUS1.5-50	1.5	50	12	50	75	78	15	14	29	—	—
SUS1.5-55	1.5	55	12	55	82.5	85.5	15	14	29	—	—
SUS1.5-56	1.5	56	12	55	84	87	15	14	29	—	—
SUS1.5-60	1.5	60	15	60	90	93	15	14	29	—	—
SUS1.5-64	1.5	64	15	60	96	99	15	14	29	—	—
SUS1.5-70	1.5	70	15	70	105	108	15	14	29	—	—
SUS1.5-75	1.5	75	15	70	112.5	115.5	15	14	29	—	—
SUS1.5-80	1.5	80	15	80	120	123	15	14	29	—	—
SUS1.5-90	1.5	90	15	80	135	138	15	14	29	—	—
SUS1.5-100	1.5	100	15	80	150	153	15	14	29	—	—



共同規格

精度等級	JIS N8級(JIS B 1702-1:1996) 舊JIS4級(JIS B 1702:1976)	齒面硬度	187HB以下
齒形	標準全齒深齒	表面處理	—
壓力角	20°	齒面精加工	切削
材質	SUS303	切齒基準面	內徑
熱處理	—	追加工	可

※ 亦可承製 SUS404 等材質的訂製品。

形狀	容許力矩 (N·m) 注 1		容許力矩 (kgf·m)		齒隙 (mm) 注 2	質量 (kg)	產品型號
	彎曲強度	面壓強度	彎曲強度	面壓強度			
S3	2.042	0.1236	(0.2082)	(0.0126)	0.08 ~ 0.18	0.04	SUS1- 15
S3	2.262	0.1432	(0.2307)	(0.0146)	0.08 ~ 0.18	0.04	SUS1- 16
S3	2.713	0.1844	(0.2767)	(0.0188)	0.08 ~ 0.18	0.06	SUS1- 18
S1	3.175	0.2324	(0.3238)	(0.0237)	0.08 ~ 0.18	0.04	SUS1- 20
S1	3.648	0.2864	(0.372)	(0.0292)	0.1 ~ 0.22	0.04	SUS1- 22
S1	4.128	0.3481	(0.4209)	(0.0355)	0.1 ~ 0.22	0.06	SUS1- 24
S1	4.37	0.3815	(0.4456)	(0.0389)	0.1 ~ 0.22	0.06	SUS1- 25
S1	5.106	0.4844	(0.5207)	(0.0494)	0.1 ~ 0.22	0.07	SUS1- 28
S1	5.603	0.5609	(0.5714)	(0.0572)	0.1 ~ 0.22	0.09	SUS1- 30
S1	6.106	0.6423	(0.6226)	(0.0655)	0.1 ~ 0.22	0.1	SUS1- 32
S1	6.865	0.7757	(0.7)	(0.0791)	0.1 ~ 0.22	0.11	SUS1- 35
S1	7.12	0.8238	(0.726)	(0.084)	0.1 ~ 0.22	0.12	SUS1- 36
S1	8.145	1.03	(0.8306)	(0.105)	0.1 ~ 0.22	0.16	SUS1- 40
S1	8.662	1.141	(0.8833)	(0.1164)	0.12 ~ 0.26	0.17	SUS1- 42
S1	9.442	1.32	(0.9628)	(0.1346)	0.12 ~ 0.26	0.19	SUS1- 45
S1	10.23	1.512	(1.043)	(0.1542)	0.12 ~ 0.26	0.21	SUS1- 48
S1	10.75	1.648	(1.096)	(0.168)	0.12 ~ 0.26	0.22	SUS1- 50
S1	12.06	2.012	(1.23)	(0.2052)	0.12 ~ 0.26	0.28	SUS1- 55
S1	12.33	2.09	(1.257)	(0.2131)	0.12 ~ 0.26	0.28	SUS1- 56
S1	13.39	2.415	(1.365)	(0.2463)	0.12 ~ 0.26	0.31	SUS1- 60
S1	14.45	2.765	(1.474)	(0.282)	0.12 ~ 0.26	0.37	SUS1- 64
S1	16.05	3.335	(1.637)	(0.3401)	0.12 ~ 0.26	0.47	SUS1- 70
S1	17.39	3.859	(1.773)	(0.3935)	0.12 ~ 0.26	0.53	SUS1- 75
S1	18.73	4.423	(1.91)	(0.451)	0.12 ~ 0.26	0.6	SUS1- 80
S1	21.43	5.672	(2.185)	(0.5784)	0.16 ~ 0.32	0.72	SUS1- 90
S1	24.12	7.082	(2.46)	(0.7222)	0.16 ~ 0.32	0.82	SUS1-100
S1	29.55	10.41	(3.013)	(1.062)	0.16 ~ 0.32	1.1	SUS1-120

S1	6.891	0.4285	(0.7027)	(0.0437)	0.1 ~ 0.22	0.06	SUS1.5- 15
S1	7.634	0.4962	(0.7785)	(0.0506)	0.1 ~ 0.22	0.08	SUS1.5- 16
S1	9.157	0.6472	(0.9338)	(0.066)	0.1 ~ 0.22	0.1	SUS1.5- 18
S1	10.72	0.8198	(1.093)	(0.0836)	0.1 ~ 0.22	0.12	SUS1.5- 20
S1	12.31	1.014	(1.255)	(0.1034)	0.12 ~ 0.26	0.15	SUS1.5- 22
S1	13.94	1.231	(1.421)	(0.1255)	0.12 ~ 0.26	0.18	SUS1.5- 24
S1	14.75	1.347	(1.504)	(0.1374)	0.12 ~ 0.26	0.19	SUS1.5- 25
S1	17.23	1.711	(1.757)	(0.1745)	0.12 ~ 0.26	0.26	SUS1.5- 28
S1	18.92	1.98	(1.929)	(0.2019)	0.12 ~ 0.26	0.29	SUS1.5- 30
S1	20.6	2.268	(2.101)	(0.2313)	0.12 ~ 0.26	0.33	SUS1.5- 32
S1	23.17	2.738	(2.363)	(0.2792)	0.12 ~ 0.26	0.39	SUS1.5- 35
S1	24.03	2.905	(2.45)	(0.2962)	0.12 ~ 0.26	0.42	SUS1.5- 36
S1	27.49	3.624	(2.803)	(0.3695)	0.12 ~ 0.26	0.48	SUS1.5- 40
S1	29.23	4.013	(2.981)	(0.4092)	0.14 ~ 0.32	0.56	SUS1.5- 42
S1	31.86	4.637	(3.249)	(0.4728)	0.14 ~ 0.32	0.57	SUS1.5- 45
S1	34.51	5.308	(3.519)	(0.5413)	0.14 ~ 0.32	0.63	SUS1.5- 48
S1	36.27	5.788	(3.699)	(0.5902)	0.14 ~ 0.32	0.71	SUS1.5- 50
S1	40.72	7.08	(4.152)	(0.722)	0.14 ~ 0.32	0.87	SUS1.5- 55
S1	41.61	7.355	(4.243)	(0.75)	0.14 ~ 0.32	0.9	SUS1.5- 56
S1	45.19	8.508	(4.608)	(0.8676)	0.14 ~ 0.32	1	SUS1.5- 60
S1	48.78	9.748	(4.974)	(0.994)	0.14 ~ 0.32	1.1	SUS1.5- 64
S1	54.17	11.77	(5.524)	(1.2)	0.14 ~ 0.32	1.4	SUS1.5- 70
S1	58.69	13.61	(5.985)	(1.388)	0.14 ~ 0.32	1.6	SUS1.5- 75
S1	63.22	15.63	(6.447)	(1.594)	0.14 ~ 0.32	1.8	SUS1.5- 80
S1	72.31	20.11	(7.374)	(2.051)	0.18 ~ 0.38	2.2	SUS1.5- 90
S1	81.42	25.19	(8.303)	(2.569)	0.18 ~ 0.38	2.6	SUS1.5-100

【注 1】表中容許力矩是在任意使用條件下計算的參考值。詳細內容請參考第 27 頁。

【注 2】齒隙是與同型號齒輪裝配在理論中心距離下的數值。

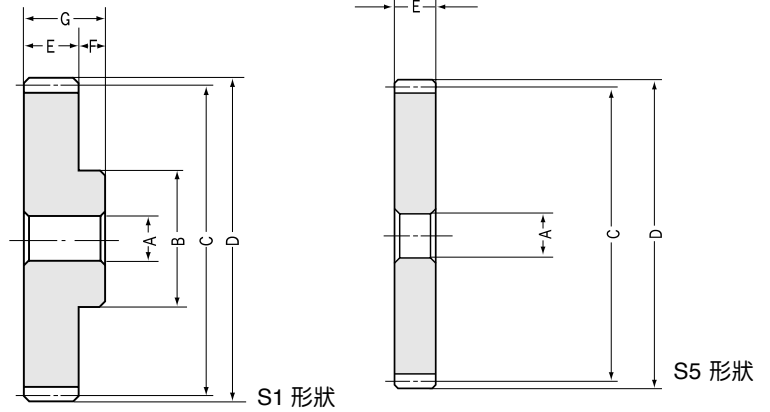

■ 模數 2

產品型號	模數	齒數	內徑	軀輪徑	節徑	齒頂圓直徑	齒幅	軀輪長	全長	腹板厚度	腹板外徑
	m	z	AH7	B	C	D	E	F	G(E)	H	I
SUS2-15	2	15	12	24	30	34	20	16	36	—	—
SUS2-16	2	16	12	26	32	36	20	16	36	—	—
SUS2-18	2	18	12	30	36	40	20	16	36	—	—
SUS2-20	2	20	12	32	40	44	20	16	36	—	—
SUS2-22	2	22	12	36	44	48	20	16	36	—	—
SUS2-24	2	24	12	38	48	52	20	16	36	—	—
SUS2-25	2	25	12	40	50	54	20	16	36	—	—
SUS2-28	2	28	12	45	56	60	20	16	36	—	—
SUS2-30	2	30	12	50	60	64	20	16	36	—	—

SUSA2-32	2	32	15	—	64	68	20	—	20	—	—
SUSA2-35	2	35	15	—	70	74	20	—	20	—	—
SUSA2-36	2	36	15	—	72	76	20	—	20	—	—
SUSA2-40	2	40	15	—	80	84	20	—	20	—	—
SUSA2-42	2	42	15	—	84	88	20	—	20	—	—
SUSA2-45	2	45	15	—	90	94	20	—	20	—	—
SUSA2-48	2	48	15	—	96	100	20	—	20	—	—
SUSA2-50	2	50	15	—	100	104	20	—	20	—	—
SUSA2-55	2	55	15	—	110	114	20	—	20	—	—
SUSA2-56	2	56	15	—	112	116	20	—	20	—	—
SUSA2-60	2	60	15	—	120	124	20	—	20	—	—
SUSA2-64	2	64	15	—	128	132	20	—	20	—	—
SUSA2-70	2	70	15	—	140	144	20	—	20	—	—

■ 模數 2.5

SUS2.5-15	2.5	15	15	30	37.5	42.5	25	18	43	—	—
SUS2.5-16	2.5	16	15	32	40	45	25	18	43	—	—
SUS2.5-18	2.5	18	15	38	45	50	25	18	43	—	—
SUS2.5-20	2.5	20	15	40	50	55	25	18	43	—	—
SUS2.5-22	2.5	22	15	44	55	60	25	18	43	—	—
SUS2.5-24	2.5	24	15	48	60	65	25	18	43	—	—
SUS2.5-25	2.5	25	15	50	62.5	67.5	25	18	43	—	—
SUS2.5-28	2.5	28	15	60	70	75	25	18	43	—	—
SUS2.5-30	2.5	30	15	65	75	80	25	18	43	—	—

SUSA2.5-32	2.5	32	15	—	80	85	25	—	25	—	—
SUSA2.5-35	2.5	35	15	—	87.5	92.5	25	—	25	—	—
SUSA2.5-36	2.5	36	15	—	90	95	25	—	25	—	—
SUSA2.5-40	2.5	40	20	—	100	105	25	—	25	—	—
SUSA2.5-42	2.5	42	20	—	105	110	25	—	25	—	—
SUSA2.5-45	2.5	45	20	—	112.5	117.5	25	—	25	—	—
SUSA2.5-48	2.5	48	20	—	120	125	25	—	25	—	—
SUSA2.5-50	2.5	50	20	—	125	130	25	—	25	—	—
SUSA2.5-55	2.5	55	20	—	137.5	142.5	25	—	25	—	—
SUSA2.5-56	2.5	56	20	—	140	145	25	—	25	—	—
SUSA2.5-60	2.5	60	20	—	150	155	25	—	25	—	—
SUSA2.5-64	2.5	64	20	—	160	165	25	—	25	—	—



規 格

精度等級	JIS N8級(JIS B 1702-1:1996) 舊JIS4級(JIS B 1702:1976)	齒面硬度	187HB以下
齒形	標準全齒深齒	表面處理	—
壓力角	20°	齒面精加工	切削
材質	SUS303	切齒基準面	內徑
熱處理	—	追加工	可

※ 亦可承製 SUS404 等材質的訂製品。

形狀	容許力矩 (N·m) 注1		容許力矩 (kgf·m)		齒隙 (mm) 注2	質量 (kg)	產品型號
	彎曲強度	面壓強度	彎曲強度	面壓強度			
S1	16.34	1.051	(1.666)	(0.1072)	0.12 ~ 0.26	0.14	SUS2-15
S1	18.09	1.216	(1.845)	(0.124)	0.12 ~ 0.26	0.16	SUS2-16
S1	21.7	1.586	(2.213)	(0.1617)	0.12 ~ 0.26	0.22	SUS2-18
S1	25.41	2.008	(2.591)	(0.2048)	0.12 ~ 0.26	0.27	SUS2-20
S1	29.18	2.484	(2.976)	(0.2533)	0.14 ~ 0.3	0.34	SUS2-22
S1	33.02	3.012	(3.367)	(0.3071)	0.14 ~ 0.3	0.39	SUS2-24
S1	34.96	3.295	(3.565)	(0.336)	0.14 ~ 0.3	0.43	SUS2-25
S1	40.85	4.181	(4.166)	(0.4263)	0.14 ~ 0.3	0.56	SUS2-28
S1	44.84	4.831	(4.572)	(0.4926)	0.14 ~ 0.3	0.66	SUS2-30

S5	48.85	5.531	(4.981)	(0.564)	0.14 ~ 0.3	0.48	SUSA2-32
S5	54.92	6.67	(5.6)	(0.6802)	0.14 ~ 0.3	0.58	SUSA2-35
S5	56.96	7.077	(5.808)	(0.7217)	0.14 ~ 0.3	0.61	SUSA2-36
S5	65.16	8.846	(6.645)	(0.902)	0.14 ~ 0.3	0.78	SUSA2-40
S5	69.3	9.807	(7.067)	(1)	0.18 ~ 0.36	0.85	SUSA2-42
S5	75.53	11.35	(7.702)	(1.157)	0.18 ~ 0.36	0.97	SUSA2-45
S5	81.8	12.99	(8.341)	(1.325)	0.18 ~ 0.36	1.1	SUSA2-48
S5	85.98	14.16	(8.768)	(1.444)	0.18 ~ 0.36	1.2	SUSA2-50
S5	96.52	17.31	(9.842)	(1.765)	0.18 ~ 0.36	1.5	SUSA2-55
S5	98.65	17.98	(10.06)	(1.833)	0.18 ~ 0.36	1.5	SUSA2-56
S5	107.1	20.84	(10.92)	(2.125)	0.18 ~ 0.36	1.7	SUSA2-60
S5	115.6	23.93	(11.79)	(2.44)	0.18 ~ 0.36	2	SUSA2-64
S5	128.4	28.99	(13.09)	(2.956)	0.18 ~ 0.36	2.4	SUSA2-70

S1	31.9	2.105	(3.253)	(0.2147)	0.14 ~ 0.28	0.26	SUS2.5-15
S1	35.34	2.437	(3.604)	(0.2485)	0.14 ~ 0.28	0.3	SUS2.5-16
S1	42.39	3.176	(4.323)	(0.3239)	0.14 ~ 0.28	0.41	SUS2.5-18
S1	49.62	4.018	(5.06)	(0.4097)	0.14 ~ 0.28	0.5	SUS2.5-20
S1	57	4.964	(5.812)	(0.5062)	0.16 ~ 0.34	0.63	SUS2.5-22
S1	64.5	6.014	(6.577)	(0.6133)	0.16 ~ 0.34	0.75	SUS2.5-24
S1	68.28	6.578	(6.963)	(0.6708)	0.16 ~ 0.34	0.82	SUS2.5-25
S1	79.8	8.339	(8.137)	(0.8503)	0.16 ~ 0.34	1.1	SUS2.5-28
S1	87.56	9.646	(8.929)	(0.9836)	0.16 ~ 0.34	1.3	SUS2.5-30

S5	95.4	11.06	(9.728)	(1.128)	0.16 ~ 0.34	0.95	SUSA2.5-32
S5	107.3	13.37	(10.94)	(1.363)	0.16 ~ 0.34	1.1	SUSA2.5-35
S5	111.2	14.18	(11.34)	(1.446)	0.16 ~ 0.34	1.2	SUSA2.5-36
S5	127.3	17.7	(12.98)	(1.805)	0.16 ~ 0.34	1.5	SUSA2.5-40
S5	135.3	19.62	(13.8)	(2.001)	0.18 ~ 0.4	1.7	SUSA2.5-42
S5	147.5	22.68	(15.04)	(2.313)	0.18 ~ 0.4	1.9	SUSA2.5-45
S5	159.7	26.05	(16.29)	(2.656)	0.18 ~ 0.4	2.2	SUSA2.5-48
S5	168	28.43	(17.13)	(2.899)	0.18 ~ 0.4	2.3	SUSA2.5-50
S5	188.5	34.86	(19.22)	(3.555)	0.18 ~ 0.4	2.9	SUSA2.5-55
S5	192.6	36.24	(19.64)	(3.695)	0.18 ~ 0.4	3	SUSA2.5-56
S5	209.2	41.99	(21.33)	(4.282)	0.18 ~ 0.4	3.4	SUSA2.5-60
S5	225.8	48.18	(23.03)	(4.913)	0.18 ~ 0.4	3.9	SUSA2.5-64

【注1】表中容許力矩是在任意使用條件下計算的參考值。詳細內容請參考第27頁。

【注2】齒隙是與同型號齒輪裝配在理論中心距離下的數值。

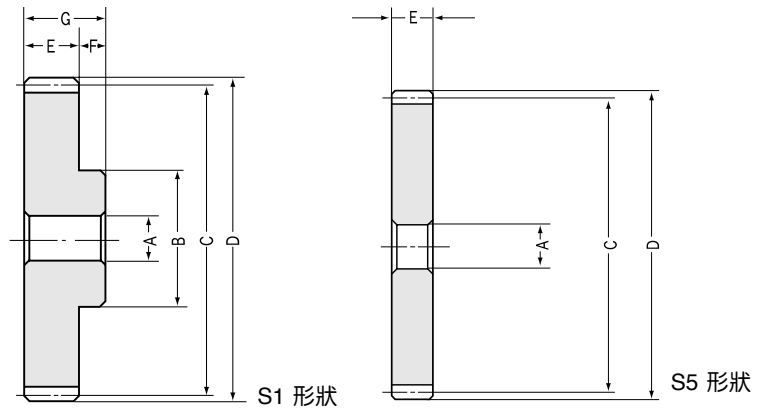

■ 模數 3

產品型號	模數	齒數	內徑	穀輪徑	節徑	齒頂圓直徑	齒幅	穀輪長	全長	腹板厚度	腹板外徑
	m	z	AH7	B	C	D	E	F	G(E)	H	I
SUS3-15	3	15	15	36	45	51	30	20	50	—	—
SUS3-16	3	16	15	38	48	54	30	20	50	—	—
SUS3-18	3	18	15	40	54	60	30	20	50	—	—
SUS3-20	3	20	15	50	60	66	30	20	50	—	—
SUS3-22	3	22	15	54	66	72	30	20	50	—	—
SUS3-24	3	24	15	58	72	78	30	20	50	—	—
SUS3-25	3	25	20	60	75	81	30	20	50	—	—
SUS3-28	3	28	20	70	84	90	30	20	50	—	—
SUS3-30	3	30	20	75	90	96	30	20	50	—	—

SUSA3-32	3	32	20	—	96	102	30	—	30	—	—
SUSA3-35	3	35	20	—	105	111	30	—	30	—	—
SUSA3-36	3	36	20	—	108	114	30	—	30	—	—
SUSA3-40	3	40	25	—	120	126	30	—	30	—	—
SUSA3-42	3	42	25	—	126	132	30	—	30	—	—
SUSA3-45	3	45	25	—	135	141	30	—	30	—	—
SUSA3-48	3	48	25	—	144	150	30	—	30	—	—
SUSA3-50	3	50	25	—	150	156	30	—	30	—	—
SUSA3-55	3	55	25	—	165	171	30	—	30	—	—
SUSA3-56	3	56	25	—	168	174	30	—	30	—	—
SUSA3-60	3	60	25	—	180	186	30	—	30	—	—

■ 模數 4

SUS4-15	4	15	20	45	60	68	40	25	65	—	—
SUS4-20	4	20	20	65	80	88	40	25	65	—	—
SUS4-25	4	25	20	84	100	108	40	25	65	—	—
SUS4-30	4	30	20	100	120	128	40	25	65	—	—

SUSA4-40	4	40	30	—	160	168	40	—	40	—	—
SUSA4-50	4	50	30	—	200	208	40	—	40	—	—



規 格

精度等級	JIS N8級(JIS B 1702-1:1998) 舊JIS4級(JIS B 1702:1976)	齒面硬度	187HB以下
齒形	標準全齒深齒	表面處理	—
壓力角	20°	齒面精加工	切削
材質	SUS303	切齒基準面	內徑
熱處理	—	追加工	可

※ 亦可承製 SUS404 等材質的訂製品。

形狀	容許力矩 (N·m) 注1		容許力矩 (kgf·m)		齒隙 (mm) 注2	質量 (kg)	產品型號
	彎曲強度	面壓強度	彎曲強度	面壓強度			
S1	55.13	3.712	(5.622)	(0.3785)	0.14 ~ 0.32	0.47	SUS3-15
S1	61.08	4.294	(6.228)	(0.4379)	0.14 ~ 0.32	0.54	SUS3-16
S1	73.25	5.593	(7.47)	(0.5703)	0.14 ~ 0.32	0.67	SUS3-18
S1	85.75	7.07	(8.744)	(0.7209)	0.14 ~ 0.32	0.97	SUS3-20
S1	98.46	8.729	(10.04)	(0.8901)	0.18 ~ 0.38	1.1	SUS3-22
S1	111.4	10.57	(11.36)	(1.078)	0.18 ~ 0.38	1.3	SUS3-24
S1	118	11.57	(12.03)	(1.18)	0.18 ~ 0.38	1.4	SUS3-25
S1	137.9	14.71	(14.06)	(1.5)	0.18 ~ 0.38	1.8	SUS3-28
S1	151.3	17.01	(15.43)	(1.735)	0.18 ~ 0.38	2.1	SUS3-30

S5	164.8	19.5	(16.81)	(1.988)	0.18 ~ 0.38	1.6	SUSA3-32
S5	185.3	23.55	(18.9)	(2.401)	0.18 ~ 0.38	2	SUSA3-35
S5	192.2	24.98	(19.6)	(2.547)	0.18 ~ 0.38	2.1	SUSA3-36
S5	220	31.25	(22.43)	(3.187)	0.18 ~ 0.38	2.5	SUSA3-40
S5	233.9	34.71	(23.85)	(3.539)	0.2 ~ 0.44	2.9	SUSA3-42
S5	254.9	40.23	(25.99)	(4.102)	0.2 ~ 0.44	3.3	SUSA3-45
S5	276.1	46.18	(28.15)	(4.709)	0.2 ~ 0.44	3.8	SUSA3-48
S5	290.2	50.39	(29.59)	(5.138)	0.2 ~ 0.44	4	SUSA3-50
S5	325.8	61.73	(33.22)	(6.295)	0.2 ~ 0.44	5	SUSA3-55
S5	332.8	64.14	(33.94)	(6.541)	0.2 ~ 0.44	5.2	SUSA3-56
S5	361.5	74.28	(36.86)	(7.575)	0.2 ~ 0.44	5.9	SUSA3-60

S1	130.7	9.06	(13.33)	(0.924)	0.18 ~ 0.38	1.1	SUS4-15
S1	203	17.26	(20.7)	(1.76)	0.18 ~ 0.38	2.1	SUS4-20
S1	280	28.3	(28.5)	(2.89)	0.2 ~ 0.44	3.4	SUS4-25
S1	359	41.7	(36.6)	(4.25)	0.2 ~ 0.44	5	SUS4-30

S5	521	77.1	(53.2)	(7.86)	0.2 ~ 0.44	6.2	SUSA4-40
S5	573	103.4	(58.5)	(10.54)	0.24 ~ 0.52	9.7	SUSA4-50

【附註】 藍色的產品型號為新產品。

【注1】 表中容許力矩是在任意使用條件下計算的參考值。詳細內容請參考第 27 頁。

【注2】 齒隙是與同型號齒輪裝配在理論中心距離下的數值。